

## Improving Net Energy Efficiency of Dimethyl Ether Production Process from Methanol

Astrid Eka Permatasari <sup>a\*</sup>, Syalaisa Nanda Syabila <sup>b</sup>, Hly Tyas Ajeng Kartika Dewi <sup>c</sup>, Rufaidah Nilam Zahra <sup>d</sup>

*Department of Chemical Engineering, Faculty of Engineering, Universitas Diponegoro, Indonesia.*

<sup>a</sup> [astridekap@gmail.com](mailto:astridekap@gmail.com), <sup>b</sup> [hlykartikaundip@gmail.com](mailto:hlykartikaundip@gmail.com), <sup>c</sup> [rufaidahnilaam@gmail.com](mailto:rufaidahnilaam@gmail.com), <sup>d</sup> [syanasyabila@gmail.com](mailto:syanasyabila@gmail.com)

Received: 20<sup>th</sup> December 2023; Revised: 8<sup>th</sup> January 2024; Accepted: 9<sup>th</sup> January 2024  
Available online: 10<sup>th</sup> January 2024; Published regularly: June 2024



### Abstract

Dimethyl ether (DME) is a source of fuel that produces clean energy for the future. Methanol can be used as a raw material for the manufacture of DME as a natural gas that is treated for synthesis. This paper evaluates how to improve net energy efficiency in DME production and how to review the net energy efficiency calculations in DME production. Methods used for production of DME are methanol dehydration, thermodynamics examination, also improving the net energy efficiency of DME with the addition of the heat exchanger (E-100), the addition of a heater (E-104) before entering a column (T-102), and moved the mixer position before the heater (E-100). By modifying the addition of a heat exchanger (E-100), heater (E-104), and changing the position of the mixer in DME production, it has been proven that it can reduce energy requirements in the dimethyl ether synthesis process from methanol and increase net energy efficiency by up to 98.83%. The results of the case study indicate that the addition heat exchanger (E-100) able to reduce the heater load after the creation process and remove the cooler (E-101) that existed before creation, then the addition of the heater (E-104) serves to reduce the load of  $Q_{cond2}$  and  $Q_{reb2}$  on columns (T-102), also the position of the mixer for the methanol recycling flow is moved before the heater (E-100) is intended to remove the heaters (E-103).

Copyright © 2024 by Authors, Published by Universitas Diponegoro and BCREC Publishing Group. This is an open access article under the CC BY-SA License (<https://creativecommons.org/licenses/by-sa/4.0>).

**Keywords:** Dimethyl ether; methanol; dehydration; net energy; efficiency

**How to Cite:** Permatasari, A.E., Syabila, S.N., Dewi, H.T.A.K., Zahra, R.N. (2024). Improving Net Energy Efficiency of Dimethyl Ether Production Process from Methanol. *Journal of Chemical Engineering Research Progress*, 1 (1), 33-41 (doi: 10.9767/jcerp.20091)

**Permalink/DOI:** <https://doi.org/10.9767/jcerp.20091>

**Supporting Information (SI):** <https://journal.bcrec.id/index.php/jcerp/article/downloadSuppFile/20091/5125>

### 1. Introduction

The increasing global environmental pollution and energy supply issues have drawn attention to dimethyl ether (DME), a multi-source, multi-purpose product [1]. Syngas, which is created from natural gas, coal, or biomass, can be used to make DME [2]. So, Dimethyl Ether (DME,  $H_3COCH_3$ ) is regarded as a meaningful alternative fuel as it has a comparably high energy density [3], can easily be stored on vehicles, can be produced via different renewable

pathways, has a high Cetane number and is therefore suitable for use in efficient and durable compression ignition engines [3]. Also, cosmetic manufacturers use DME as an alternative to chlorofluorocarbon (CFC) propellants, which destroy the ozone layer [4]. Then, China is one of the prominent providers and consumers of DME that use it as an alternative to LPG and diesel fuel in several industries and products such as cosmetics, lighters [5,6].

Formation of DME from methanol through an indirect process which is dehydration process of methanol [7] (Figure 1). The reaction proceeds under certain conditions without producing a

\* Corresponding Author.

Email: [astridekap@gmail.com](mailto:astridekap@gmail.com) (A.E. Permatasari)

reaction side [8]. The DME synthesis process was chosen for this graduation project due to its growing significance on a global scale in terms of energy and environmental benefits, as well as the appropriate level of personal interest in the subject [9]. However, the current DME synthesis process lacks an energy efficiency concept, posing challenges for economic sustainability.

To enhance DE production from both economic and production perspectives, this research will investigate the design of a methyl chloride plant using simulations that consider aspects of energy efficiency. Research studies indicate that addressing this issue can be accomplished by implementing sustainable design procedures at various stages of the process. Optimizing energy usage in the industry is crucial, aligning with key targets in the industrial sector.

As for previous research on energy efficiency of dimethyl ether purification process by utilizing dividing wall columns [10], and energy efficient methanol to dimethyl ether processes combined with water containing methanol recycling [11]. The objective of this research work is to improve net energy efficiency in DME production and how to review the net energy efficiency calculations in DME production.

## 2. Research Methods

### 2.1. Methanol Dehydration

The most basic ether is DME, sometimes referred to as methoxy methane, wood ether, diethyl oxide, or methyl ether [12]. At normal circumstances, it is a colorless, somewhat narcotic, harmless, and extremely combustible gas; but, at mild pressure, it can be handled like a liquid. DME shares several characteristics with Liquefied Petroleum Gas (LPG) [13].

Therefore, based on the matured technology of LPG application, as far as storage, transportation, and usage, no remarkable problem for the use of DME exists. The reaction of DME synthesis is mainly dehydration of methanol that is exothermic and reversible. In the current work, the rate expression has been selected from [14].

Production of DME is carried out through catalytic dehydration of methanol through zeolitic acid catalysts [15]. The main reaction is as follows:

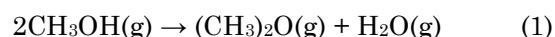

On the process flow diagram, it shows 50,000 metric tons per year with a purity of 99.5 wt% of the DME products produced. Fresh methanol is pumped with P-100 to be preheated by the heat exchanger (E-101). Fresh Methanol (Stream 3) is combined with the recycled reagent (Stream 13) in the vessel (V-100), then sent to the fixed-bed reactor (CRV-100) operating between 250 °C and 370 °C. The single-pass conversion of the methanol in the reactor is 80%.

The reactor output (Stream 5) is then cooled by the thermal exchanger (E-203) before being shipped to the first column of the two distillation columns: T-100 and T-101. DME products are taken overhead from the first distillery column (T-100), the product is mixed with methane and water towards the second distilling column (T-101).

The second distillation column (T-202) separates water from unused methanol. The output of the second distillery column is divided into methane products that are recycled back through stream 11 and then pumped with P-101 to the front end of the process (Stream 13) and back to the columns (V-100), as well as water

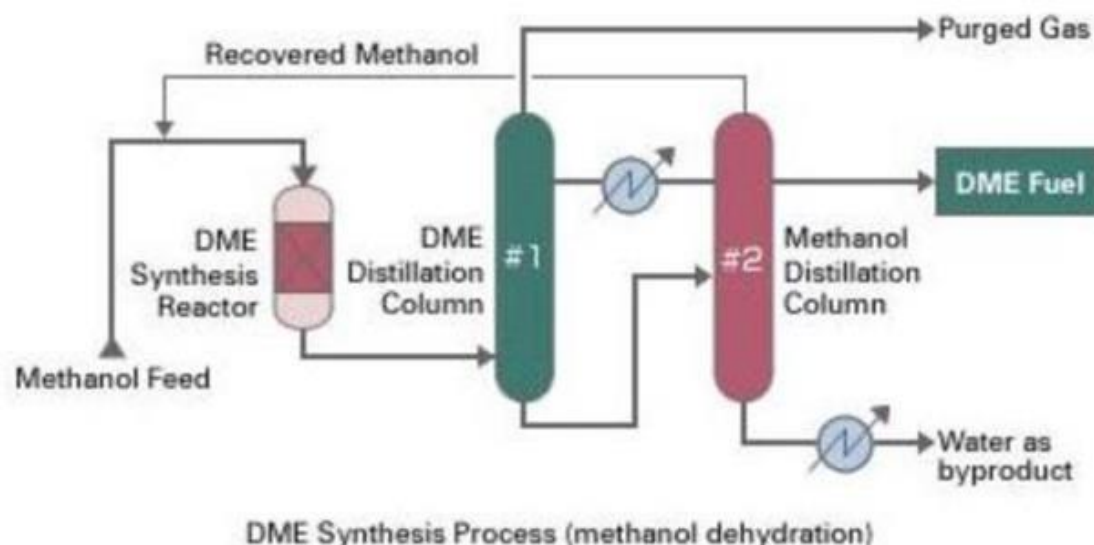
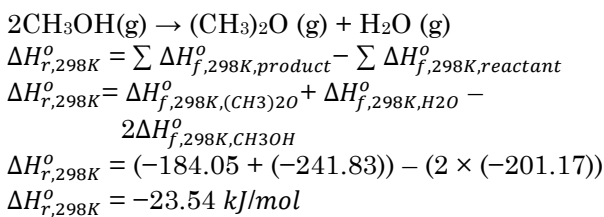

Figure 1. Basic block diagram of DME synthesis Process (methanol dehydration) [13]

(Stream 10) that is sent to wastewater treatment (E-208) to eliminate trace amounts of organic compounds [16].

## 2.2. Thermodynamics Consideration

Thermodynamic examination is used to determine the nature and direction of reactions, i.e. exothermic / endothermic and reversible / irreversible [17]. In the process selected in this simulation, one reactor is used, which is where the methanol dehydration process occurs [18]. As for the main reaction in the reactor (Equation (1)), the value of  $\Delta H_{f,298K}^o$  of each component and  $\Delta H_{r,298K}^o$  at a temperature of 298K can be seen in Table 1. Based on the data in Table 1, the  $\Delta H_{r,298K}^o$  reaction is obtained as follow:



Based on the calculations, we get the value  $\Delta H_{r,298K}^o = -23.54 \text{ kJ/mol}$  with negative value that the reaction is exothermic.

The value  $\Delta G_{f,298K}^o$  of each component at a temperature of 298K can be seen in Table 2. Based on the data in Table 2, the  $\Delta G_{r,298K}^o$  of main reaction is obtained as follow:

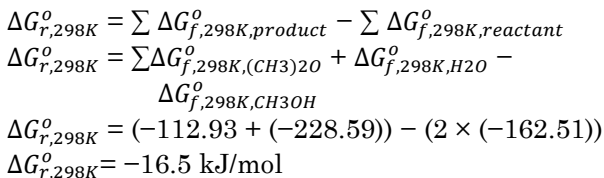

The magnitude of the equilibrium constant ( $K$ ) at 298 K can be calculated as:

$$\ln K_{298} = -\Delta G_{r,298K}^o / RT \quad (2)$$

$$\ln K_{298} = -(-16.5 \text{ kJ/mol}) / (8.314 \text{ kJ/mol})(298 \text{ K})$$

$$\ln K_{298} = 0.006659$$

$$K_{298} = 1.00668$$

Table 1. Enthalpy formation of components and enthalpy of reaction of the main reaction

Compounds	Molecular Formula	$\Delta H_{f,298K}^o$ (kJ/mol)
Methanol	CH <sub>3</sub> OH	-201.17
Dimethyl ether	(CH <sub>3</sub> ) <sub>2</sub> O	-184.05
Water	H <sub>2</sub> O	-241.83

At reactor temperature of 260 °C (533.15 K) the magnitude of the equilibrium constant ( $K$ ) can be calculated as follow:

$$\ln K_{533.15} / K_{298} = \Delta H_{r,298K}^o / R \times (1/T - 1/T_{ref}) \quad (3)$$

$$\ln K_{533.15} / 1.00668 = -(-23.54 \text{ kJ/mol}) / (8.314 \text{ kJ/mol}) \times (1/533.15 - 1/298)$$

$$K_{533.15} = 0.99579$$

Based on the calculations we have done, we get  $K$  at 533.15 K = 0.99579 and the reaction occurs reversibly.

## 2.3. Method to Improve Net Energy Efficiency of Dimethyl Ether Production Process from Methanol

A heat exchanger addition is used to exchange heat between the reactor output stream and the reactor inlet stream (CRV-100). The temperature of the reactor output stream (CRV-100) is 370.5 °C and its heat is transferred to the reactor stream (CRV-100) through the heat exchanger (E-102) for reaction preparation. After exiting the heat exchanger housing (E-102), the flow to the reactor (CRV-100) must reach operating conditions. A heater (E-104) was added to reduce the load on the distillation column (T-101). There was no heating (E-104) in the pre-creation process, so the heater (E-104) was added before the distillation column (T-101). The mixer position for the first recycle stream is moved after the heater (E-100) and before the heater (E-100). If the recycle stream arrives after the heater (E-100), the recycle stream requires operating conditions ready to enter the reactor. The temperature is 260 °C and the pressure is 1.8 bar, so the previously required heater (E-100).

Formula for calculating the net energy in the production process of dimethyl ether from methanol is as follows:

$$NE = \frac{BD - MD}{BD} \times 100\% \quad (4)$$

where,  $NE$  is equal to net energy (kJ/mol),  $BD$  is equal total heat required of the basic design (kJ/mol), and  $MD$  is equal to total heat required of the modified design (kJ/mol).

Table 2. Gibbs' free energy formation of components on the reactor

Compounds	Molecular Formula	$\Delta G_{f,298K}^o$ (kJ/mol)
Methanol	CH <sub>3</sub> OH	-162,51
Dimethyl ether	(CH <sub>3</sub> ) <sub>2</sub> O	-112,93
Water	H <sub>2</sub> O	-228,59

### 3. Results and Discussion

#### 3.1. Comparison of Basic and Modified Process Flow Diagram

The simulation of the process of forming dimethyl ether from the methanol dehydration process using Aspen HYSYS is depicted in Figures 2 and 3 with respect to basic process and modified process, respectively, while the mass and energy balance is presented in Table S1 (Supporting Information). Meanwhile, process flow diagram (PFD) of the basic process and modified process are presented in Figures 4 and 5, respectively.

#### 3.2. Evaluation of Net Energy of Modified Process

##### 3.2.1. Heat exchanger additional effect

The addition heat exchanger serves to exchange heat from the outflow of the reactor and the flow that enters the reactors (CRV-100). The outflow reactor (CRV-100) has a temperature of 370.5 °C transferred the heat into the flow toward the reactor (CRV-100) for the preparation of reaction through the heat exchangers (E-102). It is

expected that after exiting the shell heat Exchanger (E-102) the flow towards the reactor (CRV-100) have reached the operating condition. The effect of the addition of the heat exchanger (E-102) can dry up the work and reduce the energy required by the heater (E-100) by using the heat from the outflow of the reactor. The other effect is that the output flow of a reactor no longer needs to use a cooler to lower the temperature before entering the distillation column. (T-100). Therefore, energy consumption can be minimized.

Based on Table 3 and Table 4, it can be seen that the  $Q_{heat}$  requirement on the heater (E-100) can be reduced to  $7.80E+06$  kJ/h. See also in Table 4 which originally before the creation of the process requires  $Q_{cool}$  (E-101), after creation the process can be eliminated.

##### 3.2.2. Heater addition effect (E-104) before Column (T-101)

Heaters (E-104) were added to reduce the workload of the distillation column (T-101). In the process before creation there was no heater (E-104) so that the input into the column (T-101) was

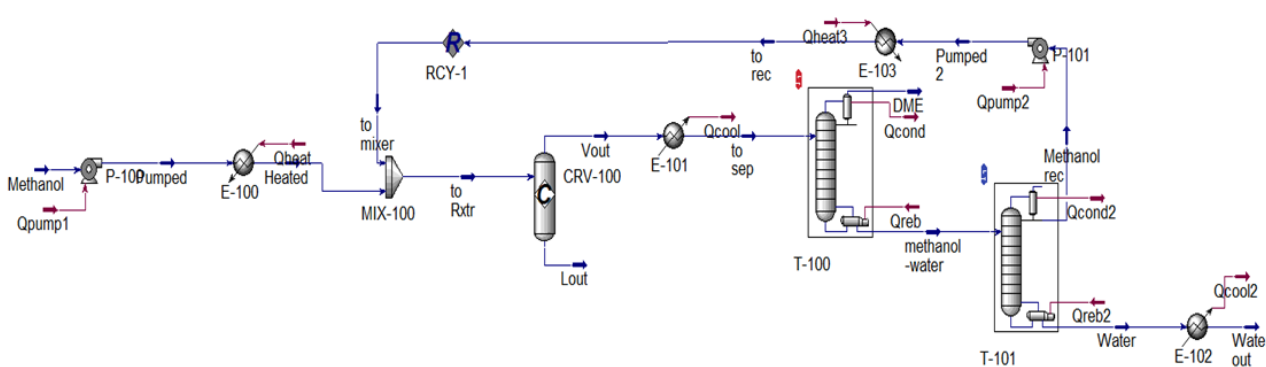

Figure 2. Aspen HYSYS simulation of basic process before process creation

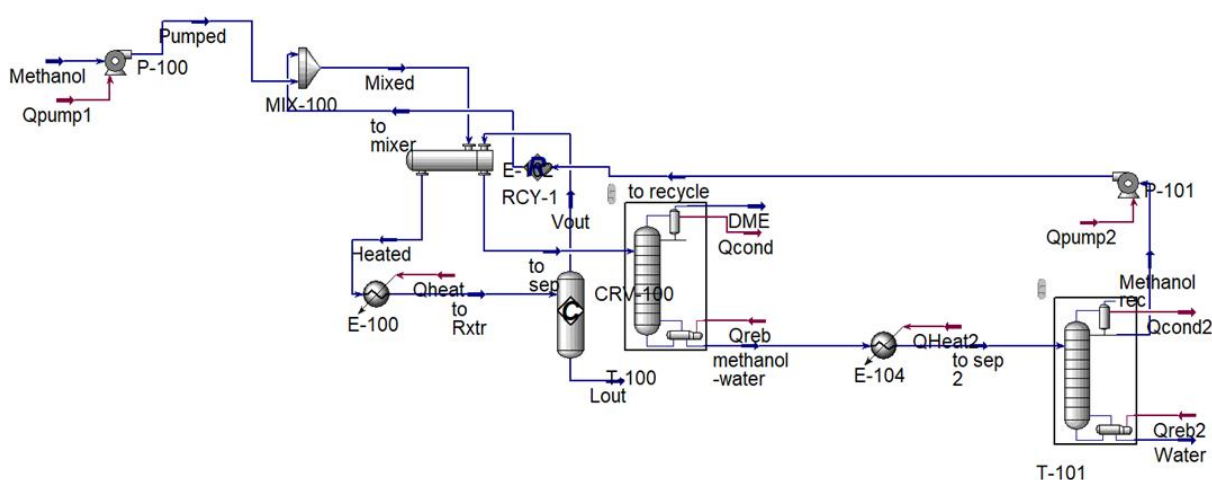

Figure 3. Aspen HYSYS simulation of modified process after process creation

liquid. After adding the heater (E-104), the input of the columns (T-101) was raised to 89 °C and was in a steam-liquid equilibrium condition. This affects the workload of the condensers and reboilers on the columns. (T-101). Another effect of this creation is the top 10 compounds of methanol that will recycle to more than ever before.

Based on Table 3 and Table 4, it is seen that  $Q_{cond2}$  and  $Q_{reb2}$  in columns (T-101) decreased to  $3.78E+06$  kJ/h and  $8.89E+03$  kJ/h which means that the workload was reduced. It can also be seen in Table S1 (Supporting Information) that the methanol composition in the flow of Methanol-rec increased to  $8.03E-01$  mole%.

### 3.2.3. Mixer position shift effect for recycled flow

The mixer position for the initial recycling flow is after the heater (E-100) is moved before the

heaters (E-100). When the recycled flow comes in after the heater (E-100), then the recycle flow needs operating conditions that are ready to enter the reactor, the temperature is 260 °C and the pressure is 1.8 bar so that the previously needed the heater (E-103) to raise the temperature. Therefore, the recycled flow goes in before the heater (E-100), in this flow the pressure condition is already the same is 2 bar and the temperature difference is not too far away so that it can be merged directly. Further heating before entering the reactor can take advantage of HE (E-102) and heater (E-100).

Based on this, the heater (E-103) before the creation of the process can be removed to reduce the workload of energy required. Based on Table 3 and Table 4, it can be seen that no more heater (E-103) is needed on the recycling stream before

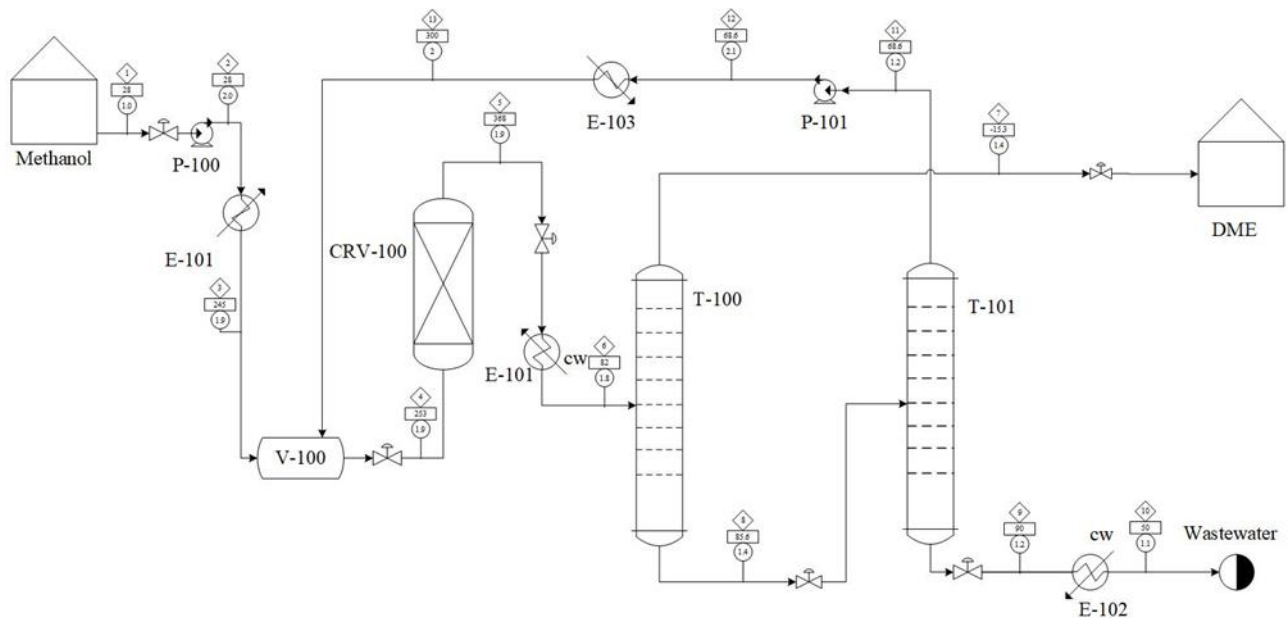

Figure 4. Process Flow Diagram (PFD) of basic process before process creation

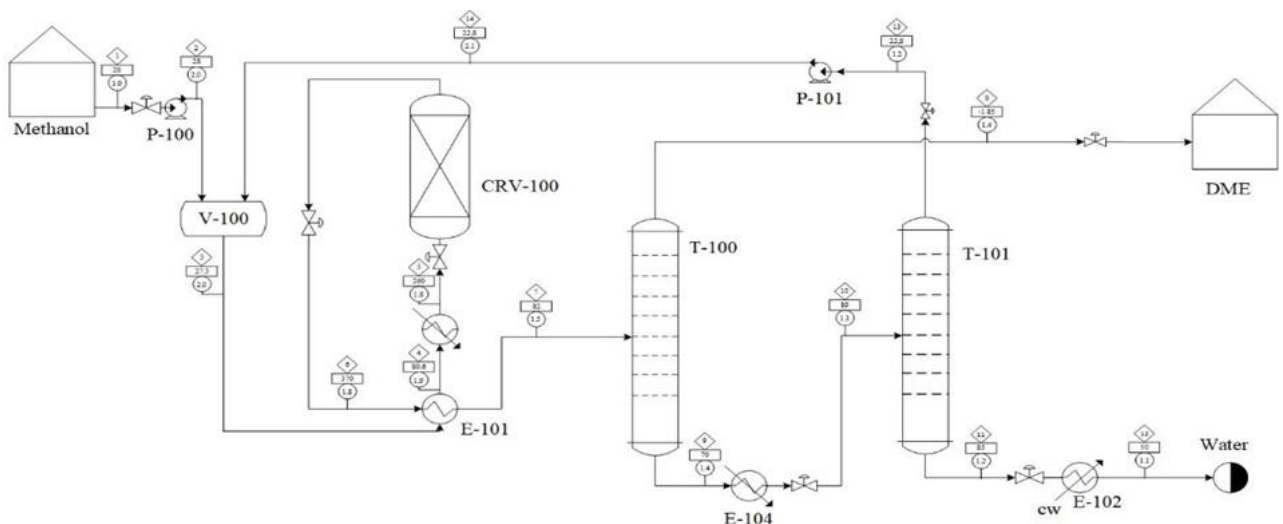

Figure 5. Process Flow Diagram (PFD) of modified process after process creation

the process is created, even the heater (E-100) can still reduce its working load to 7.80E+06 kJ/h.

**3.2.4. Evaluation of net energy of modified process**

The calculation table of the heating and cooling media requirements in forming dimethyl ether through the methanol dehydration process before and after the process creation is presented in Tables 3-6. Net energy was calculated based on Equation 2 resulted in NE = 98.83 %.

Based on the calculations above, the modified process is feasible to be applied in DME synthesis plant. By modifying the addition of a heat

exchanger (E-100), heater (E-104), and changing the position of the mixer in DME production, it has been proven that it can reduce energy requirements in the dimethyl ether synthesis process from methanol and increase net energy efficiency by up to 98.83%.

**4. Conclusion**

Based on this research, net energy efficiency can be increased by adding a heat exchanger (E-100), heater (E-104), and changing the position of the mixer before DME production will result in an increase in net energy efficiency of 98.83%. This gives a rise to the theory that the hot fluid and

Table 3. Results of calculation of heating and cooling media requirements prior to process creation

Energy streams of basic process								
	Unit	Qpump1	Qheat	Qcond	Qreb	Qcond2	Qreb2	Qpump2
Heat Flow	kJ/h	1.47E+03	1.35E+07	6.25E+06	1.58E+06	5.93E+06	5.89E+06	2.20E+02
	Unit	Qheat3	Qcool	Qcool2				
Heat Flow	kJ/h	2.03E+06	9.21E+06	4.86E+05				

Table 4. Results of calculation of heating and cooling media requirements after process creation

Energy streams of modified process								
	Unit	Qpump1	Qheat	Qcond	Qreb	Qcond2	Qreb2	QHeat2
Heat Flow	kJ/h	1.47E+03	7.80E+06	6.18E+06	7.51E+04	3.78E+06	8.89E+03	3.74E+06
	Unit	Qpump2	Qcool3					
Heat Flow	kJ/h	2.20E+02	4.48E+05					

Table 5. Energy analysis before process modification creation

Variables	Actual	Targeted	Available Savings	% of Actual
Total Utilities (kJ/h)	4.484E+07	2.896E+07	1.588E7	35.42
Heating Utilities (kJ/h)	2.297 E+07	1.503 E+07	7.94E6	34.57
Cooling Utilities (kJ/h)	2.187 E+07	1.393 E+07	7.94E6	36.31
Carbon Emissions (kg/h)	2.195 E+04	1.418 E+04	7773.00	35.41

Table 6. Energy analysis after process modification creation

Variables	Actual	Targeted	Available Savings	% of Actual
Total Utilities (kJ/h)	5.24E+05	5.014E+05	2.56E4	4.87
Heating Utilities (kJ/h)	2.278E+05	2.6E+05	1.28E4	4.70
Cooling Utilities (kJ/h)	2.524E+05	2.414E+05	1.28E4	5.04
Carbon Emissions (kg/h)	29.46	28.02	1.44	4.89



cold fluid at the input and output of the reactor can be used in the heat exchanger so that no additional cooler is needed, adding heater before distillation column can caused to reduce the workload of the distillation column, and changing the position of the mixer can reduce the use of additional coolers in the DME synthesis process from methanol.

## References

- [1] Al-Qadri, A.A., Nasser, G.A., Adamu, H., Muraza, O., Saleh, T.A. (2023). CO<sub>2</sub> utilization in syngas conversion to dimethyl ether and aromatics: Roles and challenges of zeolites-based catalysts. *Journal of Energy Chemistry*, 79, 418–449. DOI: 10.1016/j.jechem.2022.12.037
- [2] Liu, C., Liu, Z. (2022). Perspective on CO<sub>2</sub> hydrogenation for dimethyl ether economy. *Catalysts*, 12 (11), 1375. DOI: 10.3390/catal12111375
- [3] Soltic, P., Hilfiker, T., Wright, Y., Hardy, G., Fröhlich, B., Klein, D. (2024). The potential of dimethyl ether (DME) to meet current and future emissions standards in heavy-duty compression-ignition engines. *Fuel*, 355, 129357. DOI: 10.1016/j.fuel.2023.129357
- [4] Mondal, U., Yadav, G.D. (2019). Perspective of dimethyl ether as fuel: Part I. catalysis. *Journal of CO<sub>2</sub> Utilization*, 32, 299–320. DOI: 10.1016/j.jcou.2019.02.003
- [5] Rutkowska, M., Macina, D., Mirocha-Kubien, N., Piwowska, Z., Chmielarz, L. (2015). Hierarchically structured ZSM-5 obtained by desilication as new catalyst for DME synthesis from methanol, *Appl. Catal. B Environ.* 174–175, 336–343, DOI: 10.1016/j.apcatb.2015.03.006
- [6] Dieterich, V., Buttler, A., Hanel, A., Spliethoff, H., Fendt, S. (2020) Power-to-liquid via synthesis of methanol, DME or Fischer–Tropsch-fuels: a review, *Energy Environ. Sci.* 13, 3207–3252, DOI: 10.1039/d0ee01187h
- [7] Lotfollahzade Moghaddam, A., Hazlett, M.J. (2023). Methanol dehydration catalysts in direct and indirect dimethyl ether (DME) production and the beneficial role of DME in energy supply and environmental pollution. *Journal of Environmental Chemical Engineering*, 11(3), 110307. DOI: 10.1016/j.jece.2023.110307
- [8] Peinado, C., Liuzzi, D., Sluijter, S.N., Skorikova, G., Boon, J., Guffanti, S., Groppi, G., Rojas, S. (2024). Review and perspective: Next generation DME synthesis technologies for the energy transition. *Chemical Engineering Journal*, 479, 147494. DOI: 10.1016/j.cej.2023.147494
- [9] Alshbuki, E.H., Bey, M.M., Mohamed, A. Ala. (2020). Simulation production of dimethylether (DME) from dehydration of methanol using aspen Hysys. *Scholars International Journal of Chemistry and Material Sciences*, 03(02), 13–18. DOI: 10.36348/sijcms.2020.v03i02.002
- [10] Minh, L.Q., Van Duc Long, N., Lee, M. (2012). Energy efficiency improvement of dimethyl ether purification process by utilizing dividing wall columns. *Korean Journal of Chemical Engineering*, 29 (11), 1500–1507. DOI: 10.1007/s11814-012-0048-6
- [11] Zhang, C., Jun, K., Kwak, G., Kim, S. (2018). Energy-efficient methanol to dimethyl ether processes combined with water-containing methanol recycling: Process simulation and energy analysis. *Energy Technology*, 7(1), 167–176. DOI: 10.1002/ente.201800469
- [12] Zhang, Q., Qian, X., Fu, L., Yuan, M., Chen, Y. (2020). Shock wave evolution and overpressure hazards in partly premixed gas deflagration of DME/LPG blended multi-clean fuel. *Fuel*, 268, 117368. DOI: 10.1016/j.fuel.2020.117368
- [13] Buchori, L., Anggoro, D.D. (2021). Reaction Kinetics Study of Methanol Dehydration for Dimethyl Ether (DME) Production Using Dealuminated Zeolite Y Catalyst Reaction Kinetics Study of Methanol Dehydration for Dimethyl Ether (DME) Production Using Dealuminated Zeolite Y Catalyst. *Chemical Engineering Transactions*. 86, 1501-1506, DOI: 10.3303/CET2186251
- [14] Ardy, A., Pohan, R.D., Rizkiana, J., Laniwati, M., Susanto, H. (2019). Dehydration of methanol to dimethyl ether (DME): Performance of three types of catalyst at atmospheric pressure. *AIP Conference Proceedings*. 2085 (1), 020064, DOI: 10.1063/1.5095042
- [15] Turton, R., Joseph A.S., Debangsu B. (2018). *Analysis, Synthesis, and Design of Chemical Processes*. Prentice Hall: London
- [16] Poirier, K., Lotfi, M., Garg, K., Patchigolla, K., Anthony, E.J., Faisal, N.H., Mulgundmath, V., Sahith, J.K., Jadhawar, P., Koh, L., Morosuk, T., Al Mhanna, N. (2023). A comprehensive review of pre- and post-treatment approaches to achieve sustainable desalination for different water streams. *Desalination*, 566, 116944. DOI: 10.1016/j.desal.2023.116944
- [17] Dobladez, J.A., Maté, V.I., Torrellas, S.Á., Larriba, M., Pascual Muñoz, G., Alberola Sánchez, R. (2021). Comparative simulation study of methanol production by CO<sub>2</sub> hydrogenation with 3A, 4A and 5A zeolites as adsorbents in a PSA reactor. *Separation and Purification Technology*, 262, 118292. DOI: 10.1016/j.seppur.2020.118292
- [18] Yaws, C.L. (1999). *Chemical Properties Handbook*. McGraw-Hill.